

HOLDER FULLY SEATED

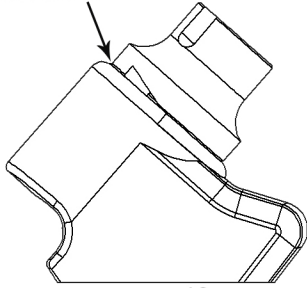

Kennametal©
KPF301 Base Block

94CDTNS

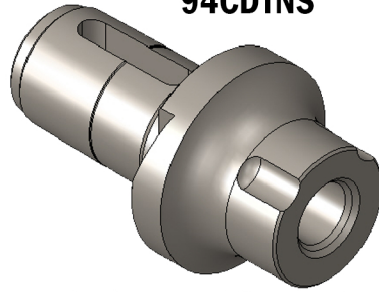

1. Matches the same 1 7/8" gage length as the Kennametal© KPF303 sleeve when installed.
2. Seats against face of Kennametal© KPF301 base block for better protection.
3. Maintains consistent gage length throughout drum when seated against face of base block.
4. Larger tire diameter than Kennametal©.
5. Use the same Kennametal© KPF301 Wedge Puller for extraction of holder.

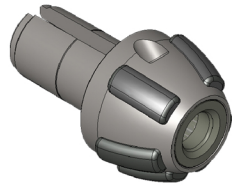

Carbide Ring Design Holder
Reduces nose wear on holders over 200%
"We Guarantee it"

47BLK76RH7.5HS

Use our patented carbide ring holders on drums using Kennametal© KPF301 base blocks.

47BLK76R76CDTN

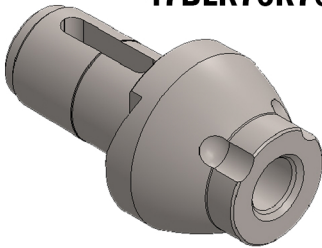

**An American family
owned and operated
business for over
40 years**

Road Milling & Reclamation-Soil Stabilization Tools

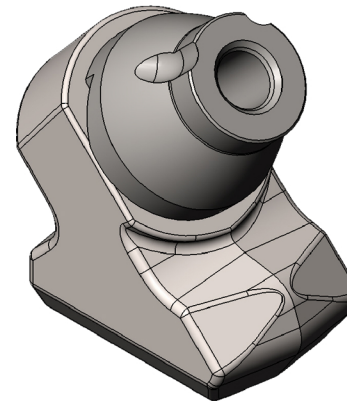

**QCBB302
QUICK CHANGE SYSTEM**

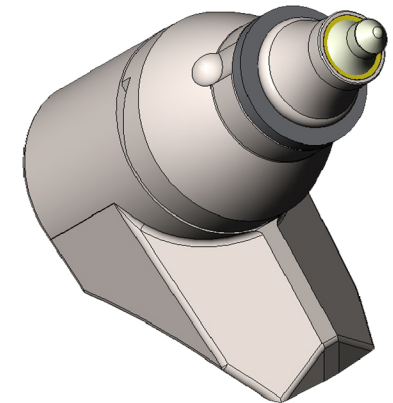

76CDTN ASSEMBLY

Ph.: 800.992.1521 - Fax 618.988.9751 - E-mail: soco1@sollamico.com

Protected by one or more of the following United States Patents: D471,211S; 6,585,326B2; 6,585,327B2; D488,170S; 6,685,273B1; 6,164,728; 6,250,535B1; 6,357,832B1; 6,371,567B1; 6,390,352B1; D460769S; 7,883,155. U.S. and foreign patents pending.
© 2011 All rights reserved by The Sollami Company.



01/24/17

**VISIT US AT
WWW.SOLLAMIMILLING.COM OR WWW.SOLLAMICO.COM**